

Runs two shifts on one battery charge – guaranteed

Advanced ergonomic design and key stability features provide optimum operator comfort and control

Industry-leading performance and efficiency from proven Jungheinrich® technology and AC motors

Sealed components for reliability in dusty or damp environments

Smart performance options to enhance order picking productivity

Optional RFID technology for precise aisle recognition



## EKS 314

### High-level order picker (3,000 lbs.)

Offering high throughput performance, the EKS 314 high-level order picker sets new standards in ergonomic design, efficiency and performance.

With a load capacity of up to 3,000 lbs. and order picking heights up to 366", this truck is specifically designed for high pick rate and high density storage applications.

Available with 24- or 36-Volt power options, the EKS can be customized to match the specific needs of your business – from various operator platform widths and mast heights to multiple base leg and fork length configurations.

Take your order picking performance to the next level:

- **High energy efficiency** – Runs two shifts on one battery charge – The industry-exclusive Jungheinrich "2 Shifts, 1 Charge" program guarantees that the EKS 314 order picker will run for two full shifts on one battery charge – with no interim charging, no battery changing and no additional charging equipment needed.
- **Industry-leading ergonomics** allow for greater operator comfort and control. The stable control handle base and ultra-comfort cushioned floor provide added comfort, while the traveling curveCONTROL feature automatically reduces speed while turning corners for optimum control.
- **Exclusive Jungheinrich components**, including the drive and hydraulic motors, software and operator controls, have undergone extensive in-house and field testing for proven reliability and performance.

Smart options are available to help enhance order picking performance and reduce operational risk:

- **End of aisle control** – RFID Transponder Technology automatically slows the truck when approaching the end of a guided aisle. Truck behaviors can be customized for slowing, stopping and lift/lower cutoff when approaching tunnels, walkways or overhead obstructions.
- **Advanced Platform Visibility option** – allows operators to see directly underneath the operator platform by way of a monitor and attached camera to detect if any personnel or objects are in the vicinity of the truck before lowering.

**JUNGHEINRICH®**

# EKS 314

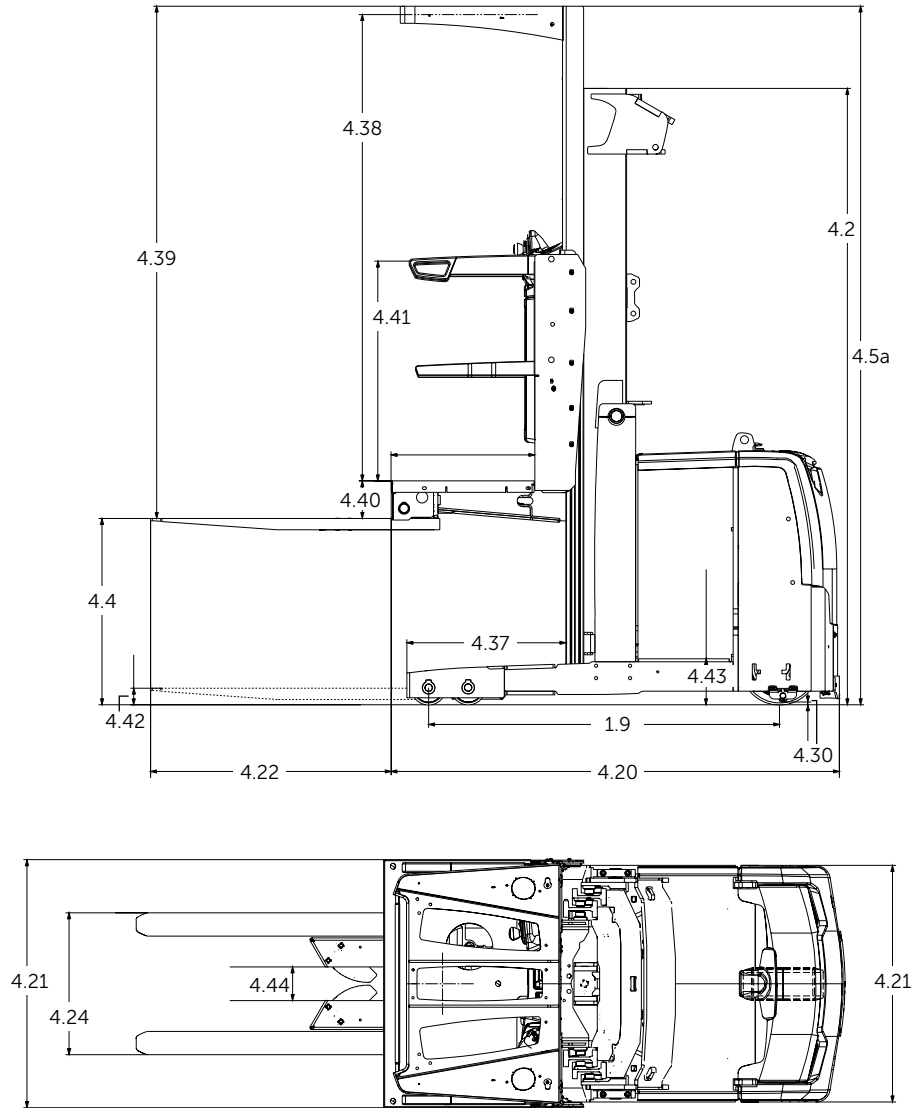

Mast Types									
	Maximum Fork Height		Overall Lowered Height		Full Free Height		Overall Extended Height		Notes
	MFH		OALH		FFH		OAEH		
	in	mm	in	mm	in	mm	in	mm	
Two-Stage Mast	138	3,505	92	2,337	3	76	227	5,768	
	148	3,759	96	2,438	3	76	237	6,022	
	168	4,267	107	2,718	3	76	257	6,530	
	190	4,826	118	2,997	3	76	279	7,089	
	212	5,385	135	3,429	3	76	301	7,648	
Three-Stage Mast	195	4,953	92	2,337	3	76	284	7,216	
	207	5,258	96	2,438	7	178	296	7,521	
	238	6,045	107	2,718	18	457	327	8,308	
	273	6,934	118	2,997	29	737	362	9,197	1
	294	7,468	127	3,226	38	965	383	9,731	1 2
	315	8,001	135	3,429	46	1,168	404	10,264	1 2
	335	8,509	143	3,632	54	1,372	424	10,772	1 2
	350	8,890	149	3,785	60	1,524	439	11,153	1 2
366	9,296	155	3,937	66	1,676	455	11,560	1 2	

1 Equipped with mast support braces

2 Requires minimum overall baseleg width. Consult your dealer for more information.

# Technical data

as of: 06/2016

Characteristics	1.1 Manufacturer			Jungheinrich		Jungheinrich			
	1.2 Model			EKS 314 (Short Chassis)		EKS 314 (Long Chassis)			
1.3 Drive	1.4 Type of operation			electric		electric			
	1.5 Load capacity / rated load			stand-on		stand-on			
Weights	1.6	Load center distance	Q	lb	T	3,000	1,360	3,000	1,360
	1.8	Load distance (load axle to fork face)	x	in	mm	24	600	24	600
	1.9	Wheelbase	y	in	mm	6.5	165	6.5	165
	2.1a	Service weight		lb	kg	61.2	1,554	66.1	1,680
	2.3	Service weight with maximum weight battery, no load		lb	kg	5,730	2,600	6,395	2,900
Wheels, Chassis	2.1a	Service weight with minimum weight battery, no load		lb	kg	8,030	3,642	9,295	4,215
	2.3	Axle loading, no load, front / rear		lb	kg	7,680	3,484	8,993	4,079
	2.3	Axle loading with rated load, front / rear		lb	kg	4,467 / 3,563	2,026 / 1,616	5,092 / 4,123	2,310 / 1,870
	3.1	Tires				2,778 / 8,270	1,260 / 3,751	3,461 / 8,800	1,570 / 3,992
	3.2	Tire size back (load) – based on 42" or 44" W baseleg <sup>3)</sup>		in	mm	polyurethane		polyurethane	
Dimensions	3.3	Tire size front (drive)		in	mm	6 x 2.88	152 x 74	6 x 2.88	152 x 74
	3.5	Wheels, number, front / rear (x=drive wheels)				13.5 x 5.5	343 x 140	13.5 x 5.5	343 x 140
	3.7	Tread width (center of tires) <sup>4)</sup>		in	mm	1x / 4		1x / 4	
	4.2	Lowered mast height		in	mm	37.8	960	37.8	960
	4.4	Maximum fork height <sup>2)</sup>		in	mm	107	2,721	107	2,721
	4.5a	Extended mast height (including platform) <sup>2)</sup>		in	mm	238	6,046	238	6,046
	4.7	Overhead guard height (top)		in	mm	327	8,310	327	8,310
	4.8	Lowered platform height		in	mm	92	2,337	92	2,337
	4.19	Maximum platform height		in	mm	10	245	10	245
	4.21	Overall length (with 42" L forks installed)		in	mm	248	6,291	248	6,291
Performance	4.20	Overall length (includes fork thickness)		in	mm	120	3,040	125	3,166
	4.22	Length to fork face (includes fork thickness)		in	mm	78.0	1,980	83	2,100
	4.21	Overall width – chassis / wheel legs		in	mm	40 / 42	1,016 / 1,067	40 / 42	1,016 / 1,067
	4.22	Fork dimensions – length x width x thickness		in	mm	42 x 4 x 2	1,280 x 100 x 50	42 x 4 x 2	1,280 x 100 x 50
	4.24	Fork carriage width <sup>1)</sup>		in	mm	30	762	30	762
	4.30	Fork spacing – out-to-out minimum / maximum		in	mm	24 / 30	610 / 762	24 / 30	610 / 762
	4.30	Ground clearance at lowest point		in	mm	0.45	12.0	0.45	12.0
	4.32	Ground clearance at center of wheelbase		in	mm	1.9	47.2	1.9	47.2
	4.35	Minimum outside turning radius		in	mm	71.2	1,808	76.2	1,935
	4.37	Length to tip of wheel arms		in	mm	27.6	702	27.6	702
	4.38	Inside operator compartment height		in	mm	81.1	2,060	81.1	2,060
	4.39	Top of fork to top of overhead guard		in	mm	89.0	2,263	89.0	2,263
	4.40	Top of fork to floor height		in	mm	6.5	166	6.5	166
	4.41	Operator compartment floor to side gate arm		in	mm	38.3	972	38.3	972
Electrical	4.42	Ground to top of fork when fully lowered		in	mm	3.0	75	3.0	75
	4.43	Ground to top of battery rollers		in	mm	8.0	203	8.0	203
	4.44	Pallet clamp opening width		in	mm	5.7	145	5.7	145
	5.1	Travel speed, loaded / no load	mph	km/h	7.5 / 7.5	12 / 12	7.5 / 7.5	12 / 12	
	5.2	Lift speed, loaded / no load	fpm	m/s	67 / 77	0.35 / 0.39	69 / 77	0.35 / 0.39	
Other	5.3	Lowering speed, loaded / no load	fpm	m/s	93 / 81	0.47 / 0.41	93 / 81	0.47 / 0.41	
	5.10	Brakes – service			regenerative		regenerative		
Electrical	6.1	Brakes – parking			electric spring-loaded		electric spring-loaded		
	6.1	Drive motor rating S <sub>2</sub> 60 min.		HP	kW	9.3	6.9	9.3	6.9
	6.2	Lift motor rating at S <sub>3</sub> 15%		HP	kW	16	12	16	12
		Battery compartment size	L	in	mm	38.4	975	38.4	975
			W			16.25	413	21.25	539
			H			32.49	825	32.49	825
	Truck voltage		Volts	24 / 36		24 / 36			
	Battery weight, minimum / maximum	lb	kg	1,950 / 2,300	885 / 1,043	1,950 / 2,300	885 / 1,043		
8.1a	Controls – drive / hydraulic			AC		AC			

1) Based on standard (common) configuration of truck with 42" baselegs.  
2) Based on common mast configuration of 238" MFH  
3) For baselegs wider than 44", wheel size is 6" x 4" (152 x 99 mm)  
4) Based on common 16.25" battery compartment

# The Jungheinrich Advantage



Optimum control

## Advanced ergonomics

The EKS 314 is equipped with the latest in ergonomic features to help ensure your operators work comfortably and confidently:

- Newly-designed operator platform – the ultra-comfort cushioned floor helps to isolate the operator's feet and legs during order picking and driving, providing enhanced stability.
- Stable control handle base – solid so that an operator can grip it securely during travel, yet retain precise control of travel and lifting functions. The angle and height of the control handle base is engineered for maximum operator comfort and control, therefore helping to enhance operator on-the-job confidence.
- Full-color interactive display panel – shows key performance indicators and truck status information in an easy-to-read manner for increased awareness.
- Side gates – nested out of the way when in the up position, giving the operator maximum access when picking product.
- Portable tote storage system – gives operators the ability to easily carry their personal tools and items from the order picker to and from other work stations.
- Single or dual USB port (optional) – provides 5-Volt / 2 Ampere power for electronic devices.
- LED lights (optional) – for increased awareness and visibility in the warehouse.
- Dual fans (optional) – for optimum operator comfort.

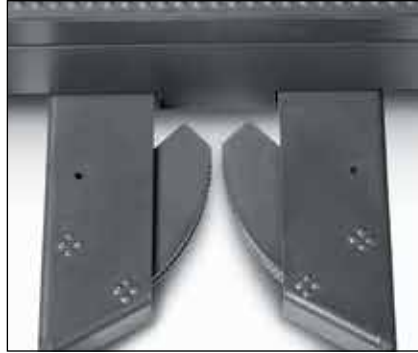

Textured tooth pallet grip

## Key productivity and efficiency features

- Jungheinrich curveCONTROL – automatically reduces speed while turning corners.
- Electric steering – reduces the effort required to control the truck, leading to increased productivity.
- Automatic pallet grip – unidirectional textured tooth edge holds the pallet center runner, automatically centering the pallet for a secure grip.

## Run longer with higher performance

60+ years of design experience has gone into the making of Jungheinrich warehouse products – with more than 400,000 Jungheinrich-built trucks in use worldwide. This extensive experience and expertise is incorporated into the EKS 314 motor technology, delivering:

- High overall performance
- Guaranteed to run 16 hours on one battery charge
- Smooth, rapid acceleration during travel, lifting and lowering
- Low power consumption
- Effective thermal management
- Reduced wear on components
- Reduced maintenance due to 1,000-hour service intervals

## Customized for your business

Optimize the EKS for your warehouse and operator preference:

- 24- or 36-Volt power
- Four battery compartment options: 14.25", 16.25", 18.25" and 21.25"
- Five simplex masts from 138" to 212", and nine triplex masts from 195" to 366"
- Seven base leg sizes from 42" to 62" long
- Eleven fork lengths, 30" to 96", adjustable side-to-side
- Three wire or rail guidance options, including Aisle Transponder Technology for customized aisle performance and two-hand operation in aisle
- Wide range of operator platform widths (standard is 42")

## Custom package options

- Freezer conditioning – includes display with integrated heater and wire mesh mast guard designed to withstand cold environments.
- Furniture picking option – includes various fork length options and a tether pole to allow operators to move across the platform (special order).
- Guidance options (wire and rail) – programmable smart truck performance features include travel speed and lift height control by way of an RFID aisle transponder.

## Parts when you need them

Jungheinrich's Parts Fast or Parts Free Guarantee ensures next-business-day delivery by 5:00 PM of all Jungheinrich parts in the United States, or they're free, including freight. For customers in Canada and Mexico, the guarantee ensures shipping of parts within 24 hours from the time the order was placed by the dealer. See your local Jungheinrich dealer for program details.

\* Programs may be subject to change without notice and may vary by region. Please ask your local Jungheinrich dealer for complete terms and conditions.